

Fukuyama Group - Group Meeting Problems

03/02/2005

1

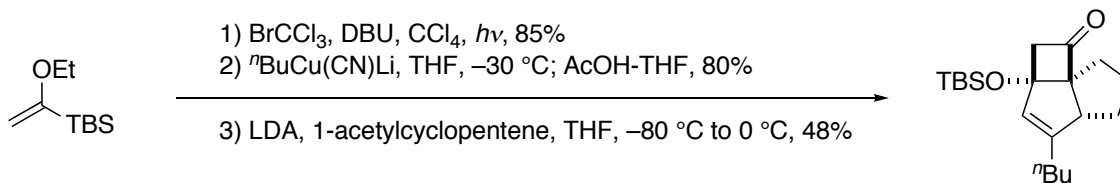

Takeda, K. *et al.*, *Org. Lett.*, **1**, 677 (1999)

2

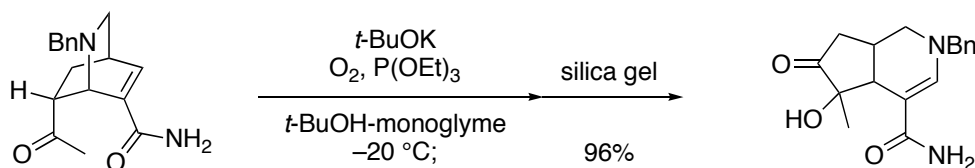

Büchi, G. *et al.*, *J. Am. Chem. Soc.*, **92**, 999 (1970)

3

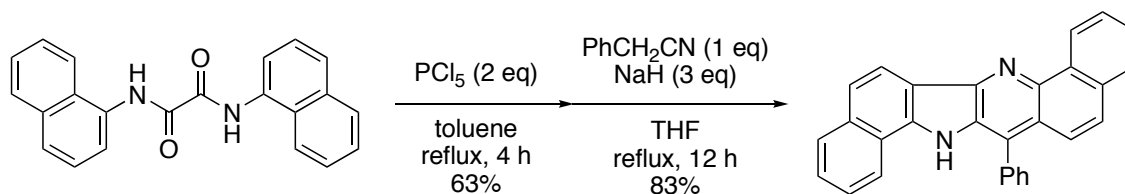

Langer, P. *et al.*, *Eur. J. Org. Chem.*, 5020 (2004)

4

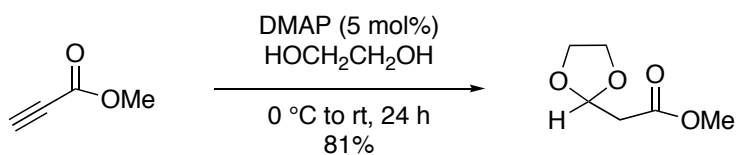

Connon, S. T. *et al.*, *Chem. Comm.*, 227 (2005)

5

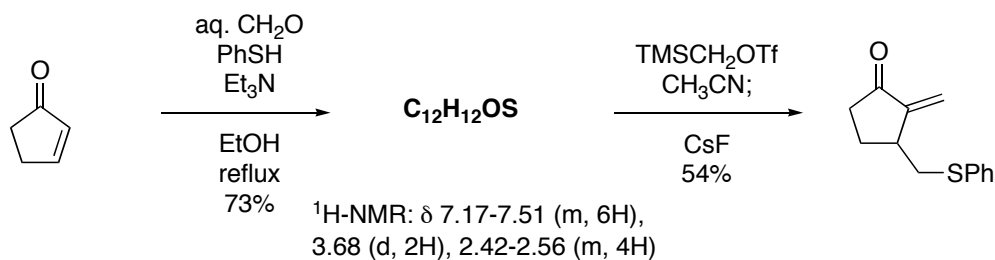

Cohen, T. *et al.*, *J. Org. Chem.*, **50**, 2965 (1985)

Fukuyama Group - Group Meeting Problems

03/08/2005

1

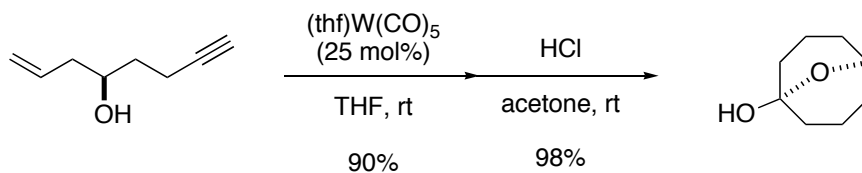

Barluenga, J. *et al.*, *Angew. Chem. Int. Ed.*, **44**, 126 (2005)

2

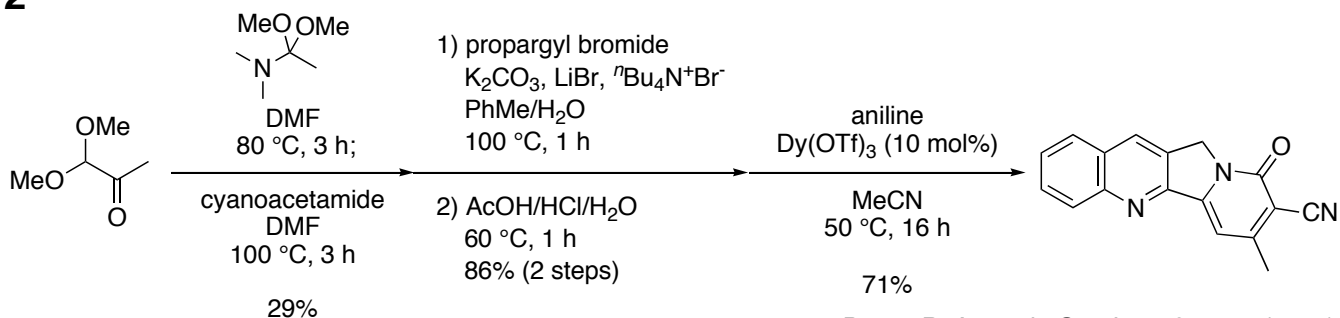

Batey, R. A. *et al.*, *Org. Lett.*, **6**, 4913 (2004)

3

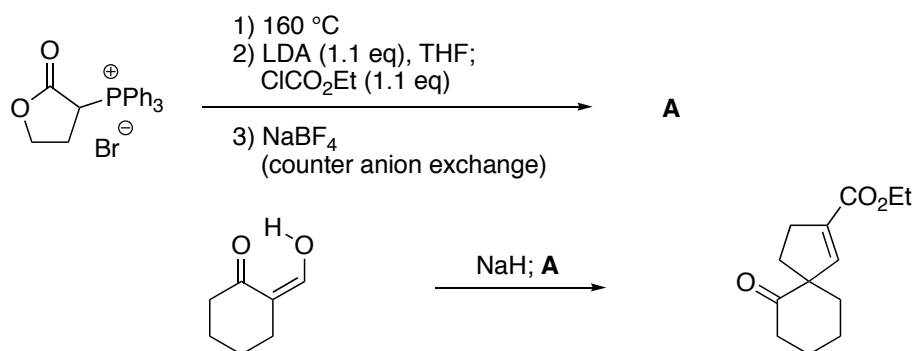

Dauben, W. G. *et al.*, *J. Am. Chem. Soc.*, **99**, 7307 (1977)

4

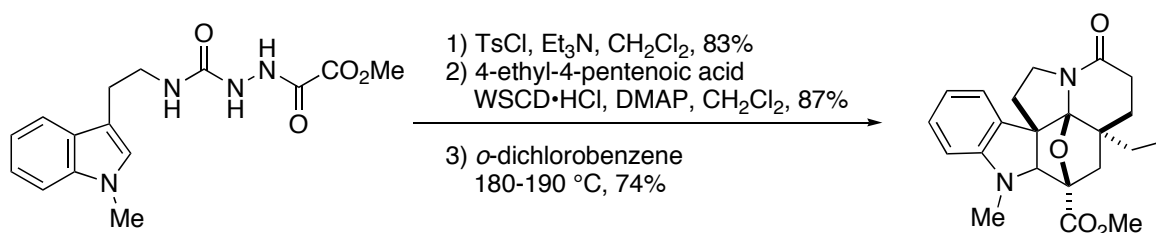

Boger, D. L. *et al.*, *Org. Lett.*, **7**, 741 (2005)

5

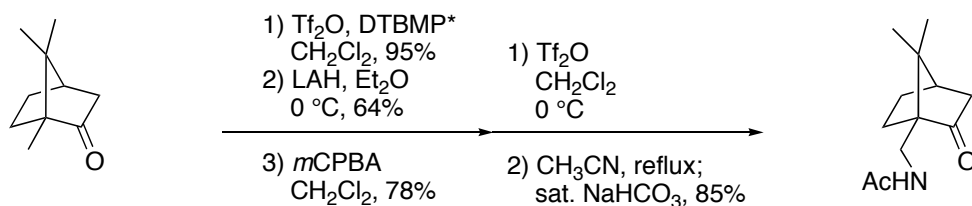

*2,6-di-*t*-butyl-4-methylpyridine

Maritez, A. G. *et al.*, *J. Org. Chem.*, **68**, 1451 (2003)

Maritez, A. G. *et al.*, *Tetrahedron*, **61**, 599 (2005)

Fukuyama Group - Group Meeting Problems

03/16/2005

1

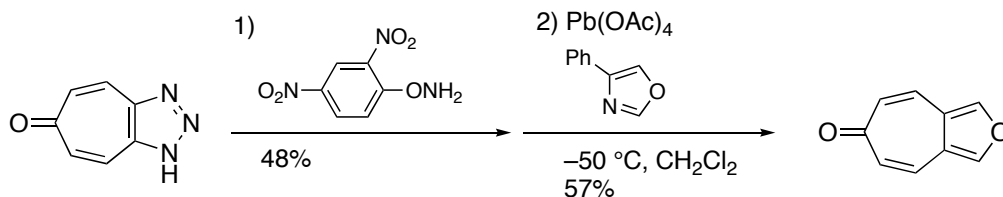

Murata, I. *et al.*, *Tetrahedron Lett.*, **35**, 8421 (1994)

2

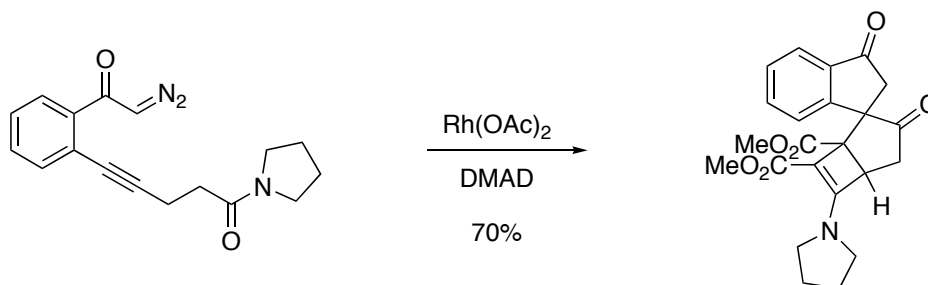

Padwa, A. *et al.*, *J. Org. Chem.*, **60**, 53 (1995)

3

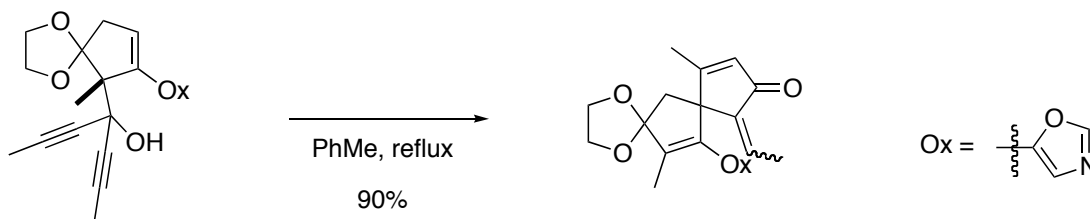

P. A. Jacobi *et al.*, *Tetrahedron Lett.*, **29**, 6865 (1988)

4

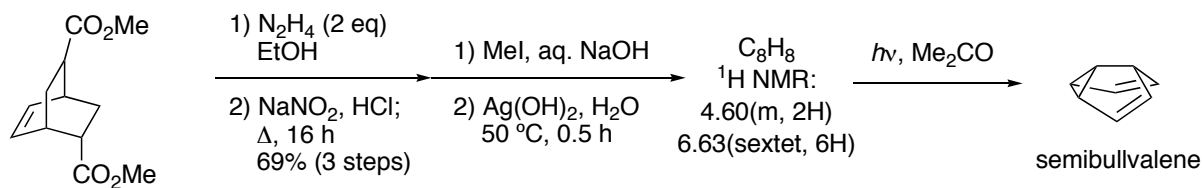

Zimmerman, H. E. *et al.*, *J. Am. Chem. Soc.*, **91**, 2330 (1969)

Zimmerman, H. E. *et al.*, *J. Am. Chem. Soc.*, **91**, 3316 (1969)

5

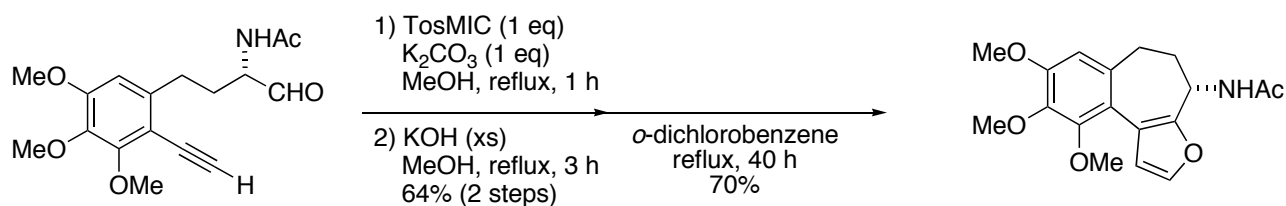

J. K. Cha *et al.*, *Tetrahedron*, **56**, 10175 (2000)

Fukuyama Group - Group Meeting Problems

03/23/2005

1

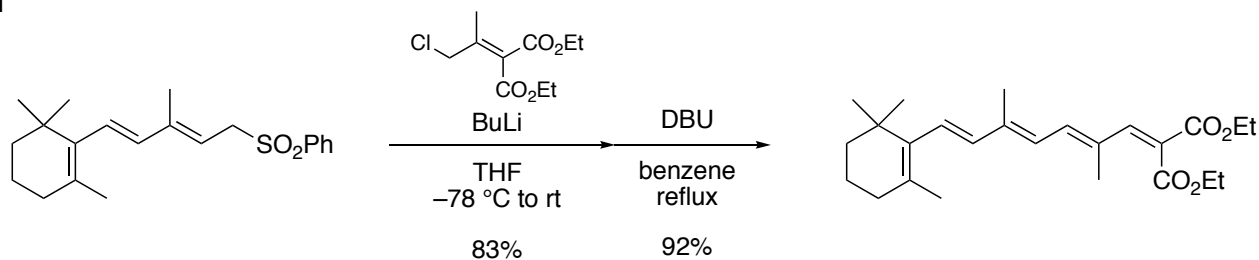

S. Koo *et al. Tetrahedron Lett.* **45**, 7023 (2004)

2

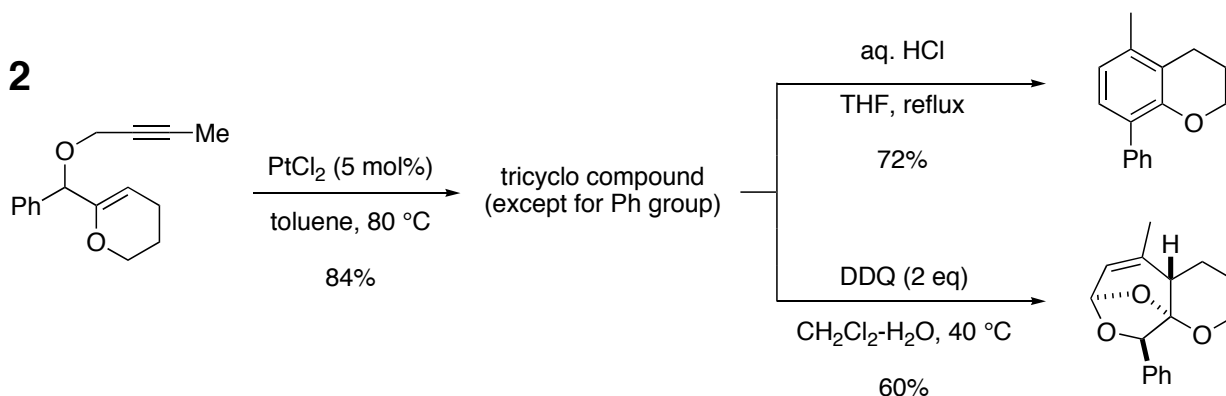

A. M. Echavarren *et al. Org. Lett.* **6**, 3191 (2004)

3

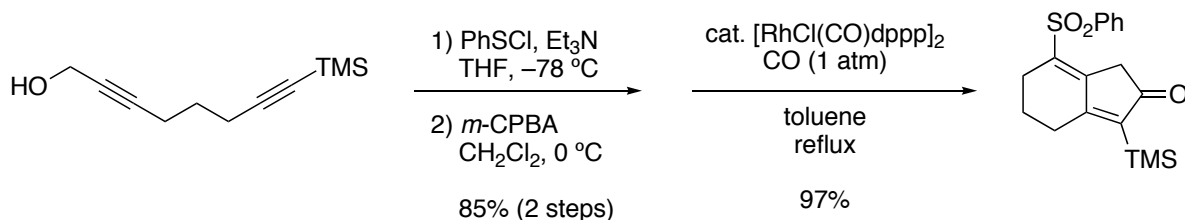

C. Murai *et al. J. Org. Chem.* **68**, 1376 (2003)

4

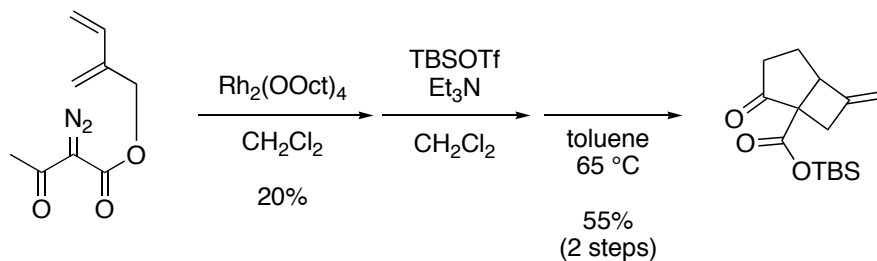

H. M. L. Davies *et al. J. Org. Chem.* **65**, 4261 (2000)

5

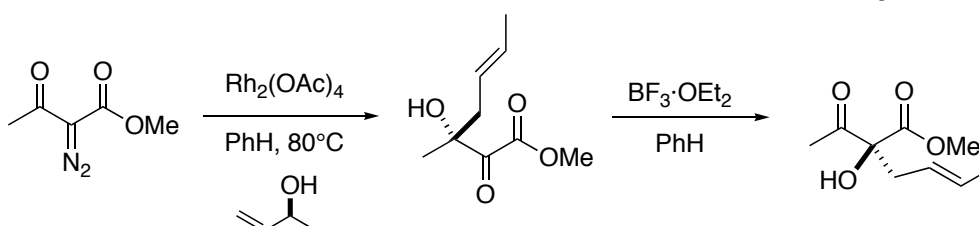

John L Wood *et al., J. Am. Chem. Soc.*, **117**, 10413 (1995)